

Adjustable Motor Bases Dimension Diagrams

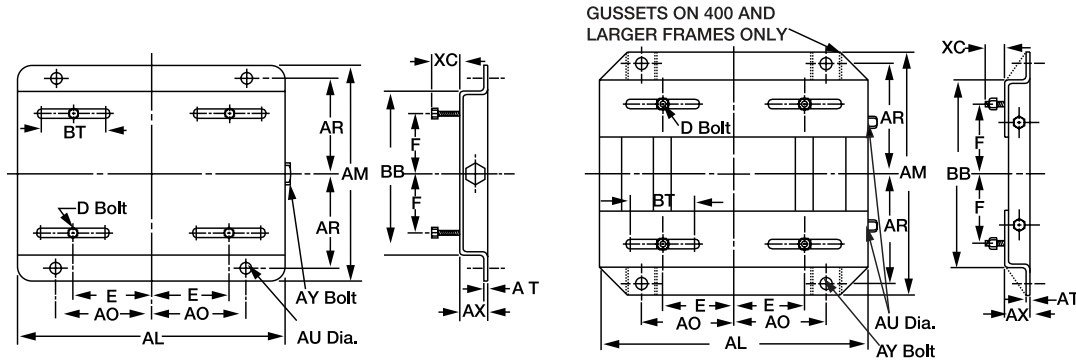

NEMA Frame	Catalog Number	E	F	AL	AM	AO	AR	AT	AU	AX	BB	BT	XC	D Bolt	AY Bolt
48	B48T	2.125	1.375	10.00	6.25	3.50	2.75								
56	B56T	2.437	1.50	10.625	6.50	3.812	2.875	0.078	0.375	1.125	4.50	3.00	0.875	5/16 x 1	3/8 x 4
143	B143T		2.00		7.50		3.375				5.50				
145	B145T	2.75	2.50	10.50	8.50	3.75	3.875	0.109	0.375	1.125	6.50	3.00	0.812	5/16 x 1	3/8 x 4
182	B182T		2.25		9.50		4.25				6.50				
184	B184T	3.75	2.75	12.75	10.50	4.50	4.75	0.140	0.50	1.50	7.50	3.00	1.50	3/8 x 1-3/4	1/2 x 5
213	B213T		2.75		11.00		4.75				7.50				
215	B215T	4.25	3.50	15.00	12.50	5.25	5.50	0.156	0.50	1.75	9.00	3.50	1.50	3/8 x 1-3/4	1/2 x 5
254	B254T				15.125		6.625				10.75				
256	B256T	5.00	4.125	17.75	16.875	6.25	7.50	0.187	0.625	2.00	12.50	4.00	1.437	1/2 x 1-3/4	5/8 x 6
284	B284T		4.75		16.875		7.50								
286	B286T	5.50	5.50	19.75	18.375	7.00	8.25	0.187	0.625	2.00	12.514	4.50	1.687	1/2 x 2	5/8 x 6
324	B324T				19.25		8.50				14.00				
326	B326T	6.25	5.256	22.75	20.75	8.00	9.25	0.187	0.75	2.50	15.50	5.25	2.187	5/8 x 2-1/2	3/4 x 9
364	B364T		5.625		20.50		9.125				15.50				
365	B365T	7.00	6.625	25.50	21.50	9.00	9.625	0.25	0.75	2.50	16.50	6.00	2.062	5/8 x 2-1/2	3/4 x 9
404	B404T		6.125		22.375		9.875				16.50				
405	B405T	8.00	6.387	28.75	23.875	10.00	10.625	0.25	0.875	3.00	18.00	7.00	2.50	3/4 x 3	3/4 x 11
444	B444T		7.25		24.625		11.00				19.25				
445	B445T	9.00	8.25	31.25	26.625	11.00	12.00	0.25	0.875	3.00	21.25	7.50	2.50	3/4 x 3	3/4 x 11
447	B447T		10.00		30.125		13.75				24.75				
449	B449T	9.00	12.50	31.25	35.125	11.00	16.25	0.312	1.125	3.00	29.75	7.50	3.00	3/4 x 3-1/2	3/4 x 11

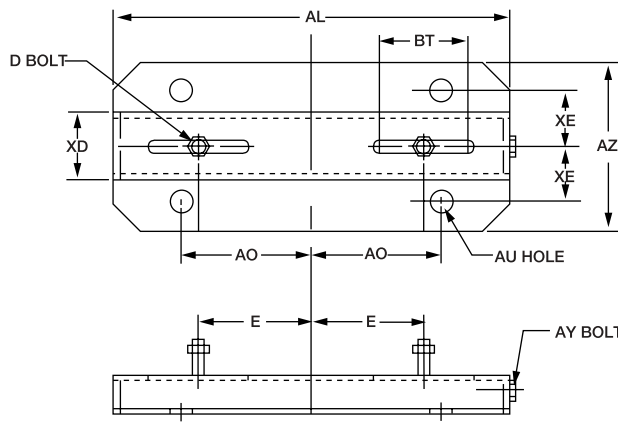

NEMA Frame	Catalog Number	E	AL	AO	AL	AU	AX	AZ	BT	XC	XO	XE	D Bolt	AY Bolt
500	B5000RLS	10.00	35.00	12.50	0.312	1.00	3.50	12.00	8.00	3.00	6.00	4.50	7/8 x 3-1/2	7/8 x 16

DIMENSIONS ARE FOR REFERENCE ONLY, CONSULT A BALDOR DISTRICT OFFICE FOR CERTIFIED DIMENSIONS